

**NOTES:**

1. This proprietary pool barrier complies with New Zealand Building Code Compliance Documents B1 Structure, F2 Hazardous Building Materials and F9/AS1, subject to:

- all products meeting the required performance specification
- site installation carried out in accordance with intent of this drawing

2. This design is based on wind zones and 330 N point load as per NZS 8500:2006.

3. Viridian safety glass options are:

- a. 10mm toughened
- b. 11.5mm toughened laminated glass with interlinking corner brackets
- c. 11.52mm toughened SentryGlas laminated glass

Interlinking corners brackets must be connected to adjacent glass panes or the building

To make allowance for the consequences of failure required by clause B1.3.4 of the Building Code B1, glass options b or c should be selected.

4. Concrete design is the responsibility of others.

5. Self closing device & latching device shall comply with the requirements of clause 3.4 of NZS 8500:2006

6. **Do not use this design if the pool barrier protects a fall of 1 metre or more. Please contact Euroglass for specific design.**

7. Refer to Euroglass installation instructions for Milano Europosts.

This post is protected by Design Registration # 413097 in New Zealand

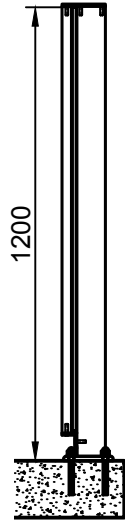
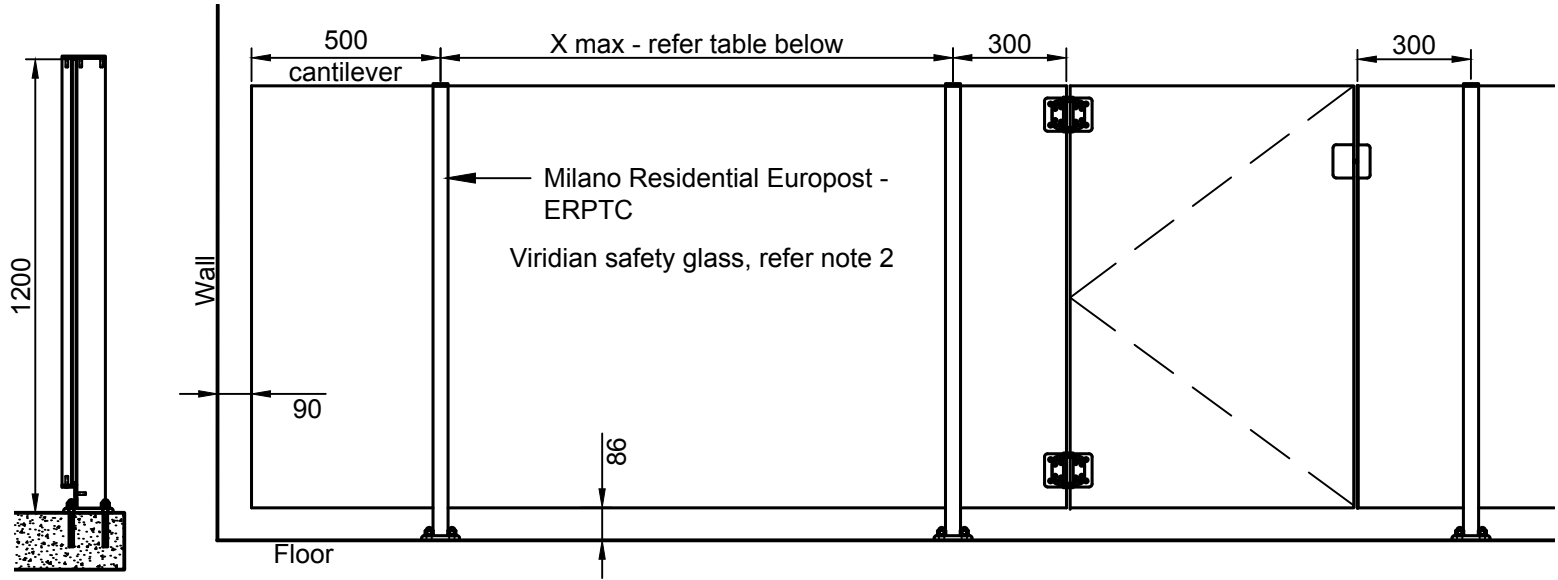

Wind Zone and Maximum Spacing of Milano Residential Europosts	
Wind zone	X max
Low	2350
Medium	2150
High	1900
Very high	1750
Extra high	1400

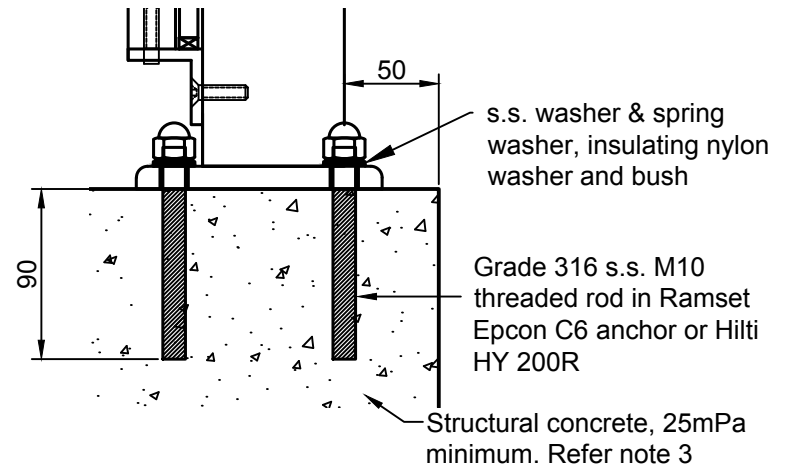

A division of Viridian Glass Ltd Partnership

**POOL BARRIER WITH MILANO RESIDENTIAL EUROPOSTS**

date 30-10-17

drawing no

scale 1:20, 1:10, 1:4

MEPF-1e