

NOTES:

1. This proprietary balustrade system complies with New Zealand Building Code Clause B1 Structure, B1/AS1 Amendment 15, B1/VM1, F2 Hazardous Building Materials and F4 Safety From Falling Third Edition, subject to:

- all products meeting the required performance specification
- site installation carried out in accordance with intent of this drawing

2. Based on barrier loads from AS/NZS 1170.1, Viridian 12mm toughened or 13.5mm toughened laminated safety glass, maximum height H above clamp are:

For residential occupancy C3 of Table 3.3 AS/NZS 1170.1

H: 1100mm high for up to extra high wind zone of 2.13 kPa

Refer drawing EFC-5 for 13.5mm glass and detail of back cover.

3. Design of support structure is the responsibility of others.

4. A handrail of 32-50mm diameter is required for stairs and ramps exceeding 1:20 slope. Refer NZBC D1/AS1.

5. Viridian safety glass options according to 22.4.3 of NZS 4223.3:2016 are:

- a. 12mm toughened safety glass with interlinking rail
- b. 13.2mm toughened laminated with glass gap clamps and a maximum pane width of 2000mm
- c. 13.52mm toughened SentryGlas laminated glass with minimum pane width of 1000mm

Interlinking rail or gap clamps must be connected to adjacent glass panes or to the building

6. The distance between fixings and the end of the channel or a joint must not exceed 300mm.

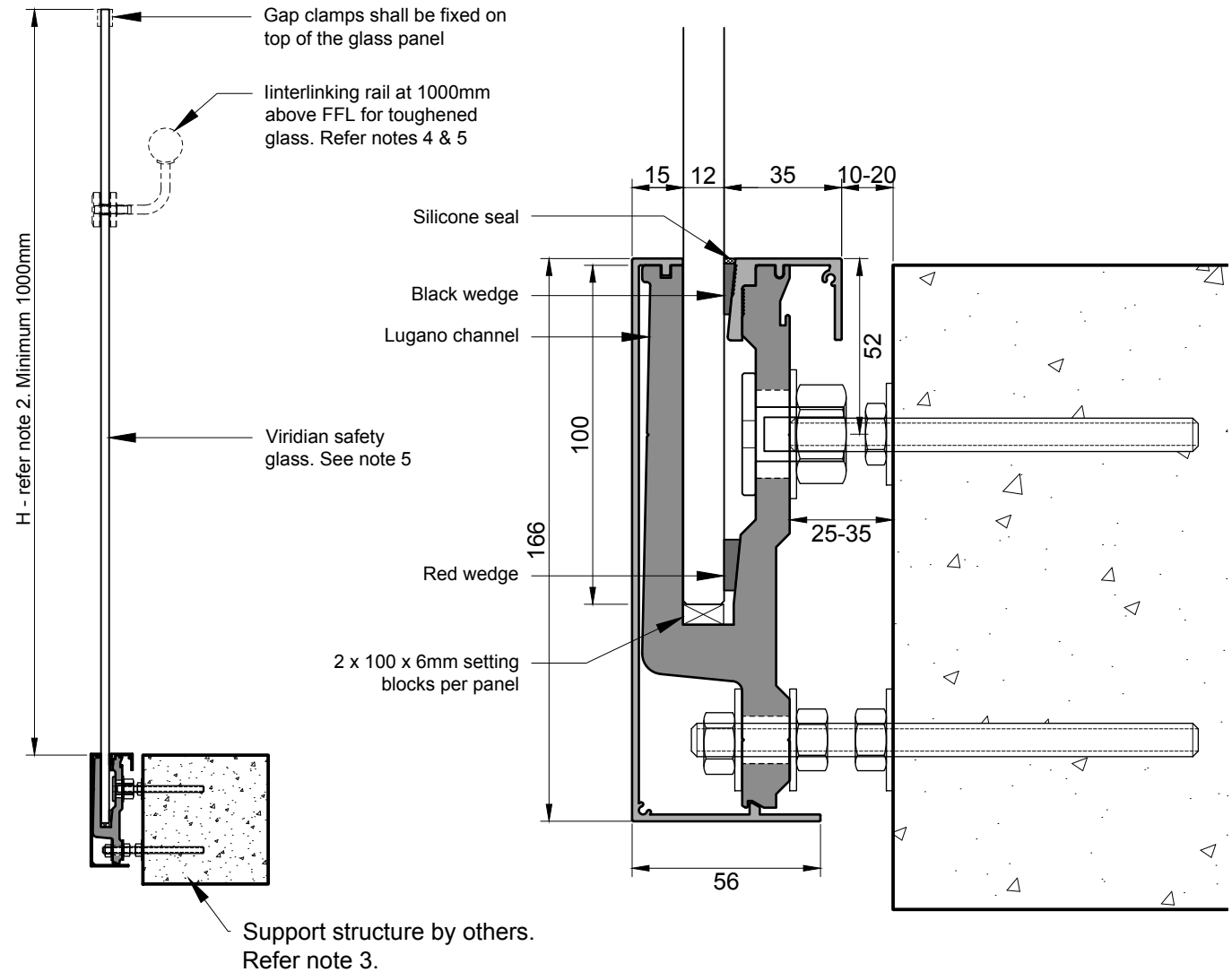

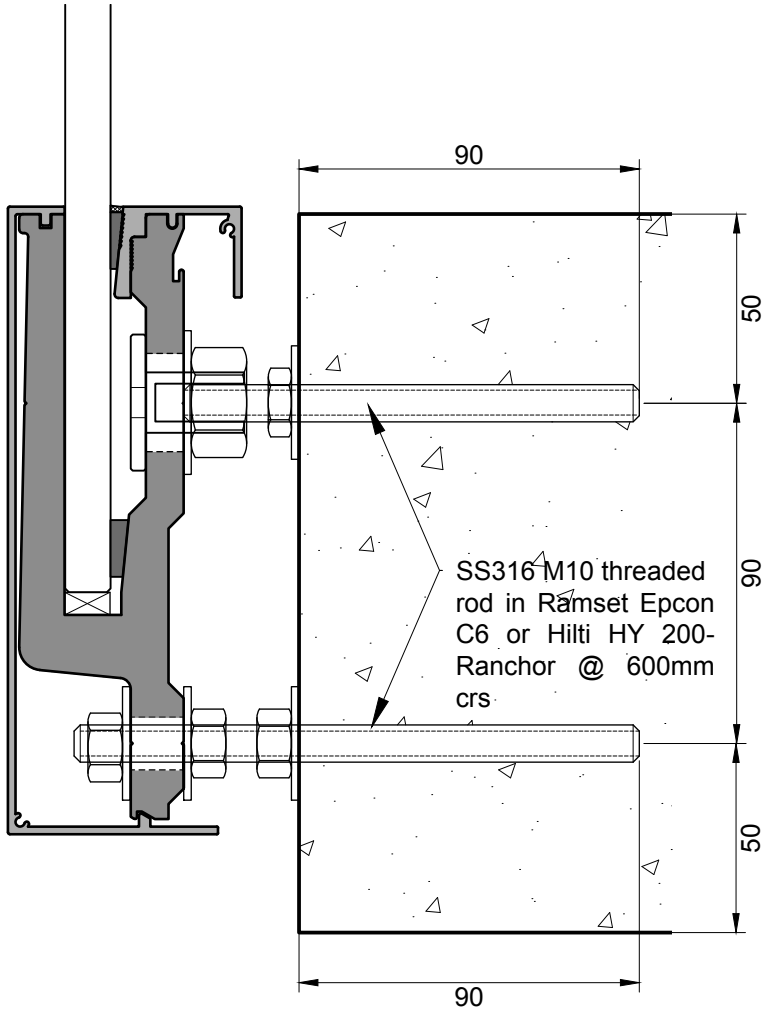

DETAIL A

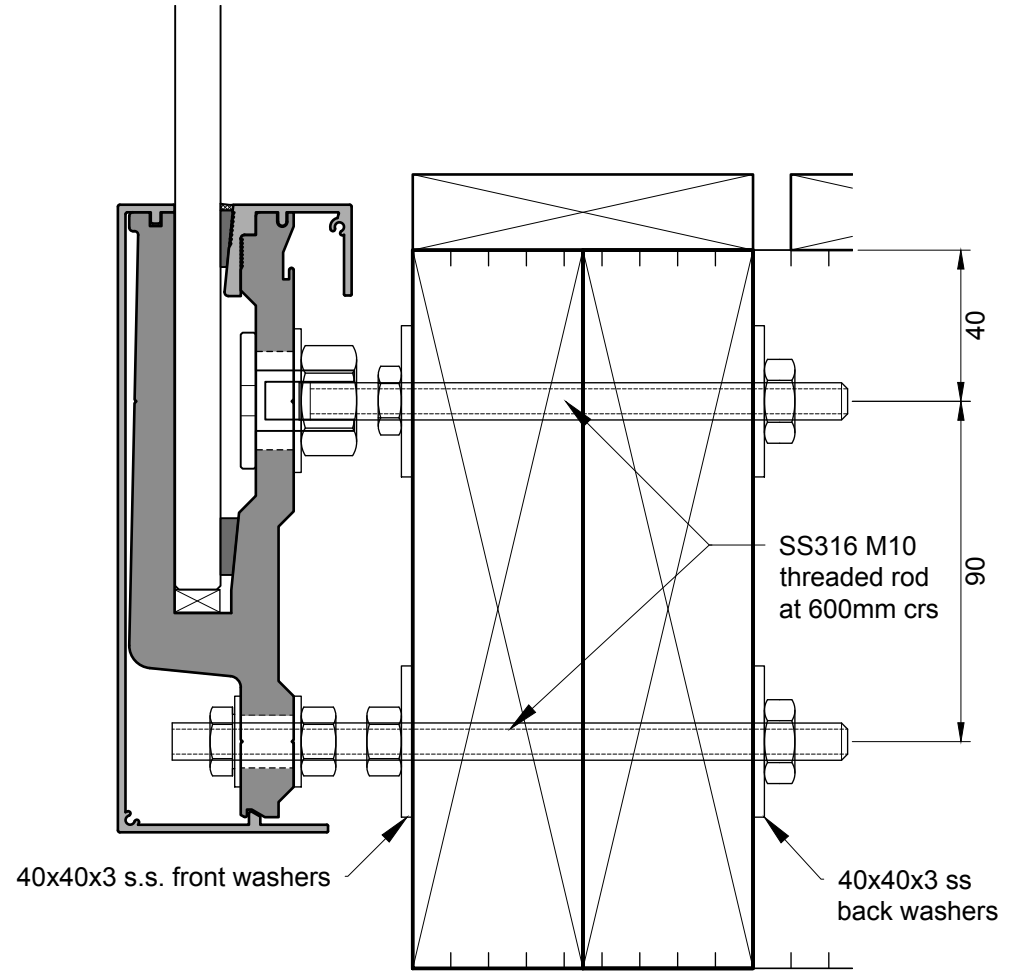

DETAIL B

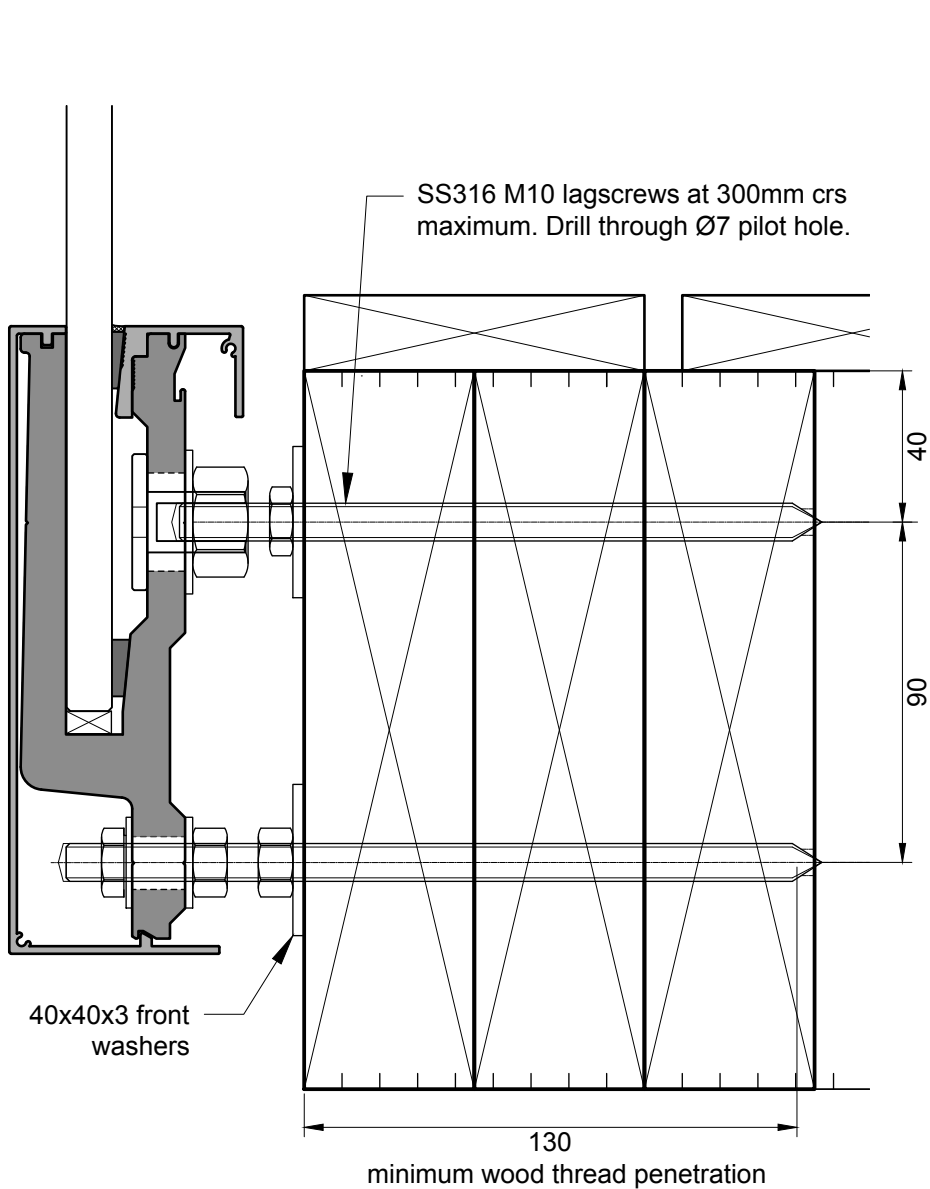

WET EXPOSED SG 8 TIMBER
DETAIL A

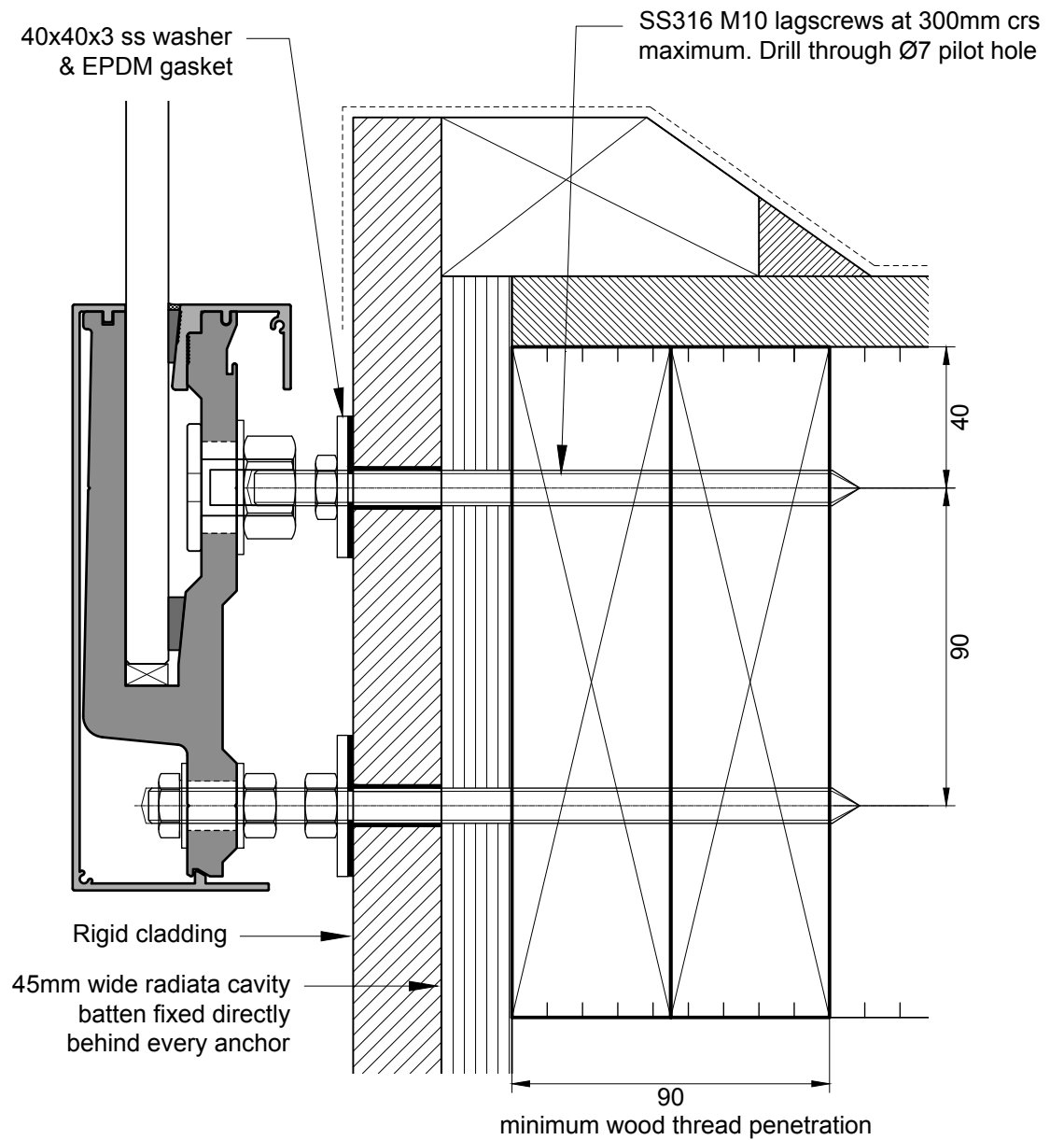

DRY CONCEALED SG 8 TIMBER
DETAIL B

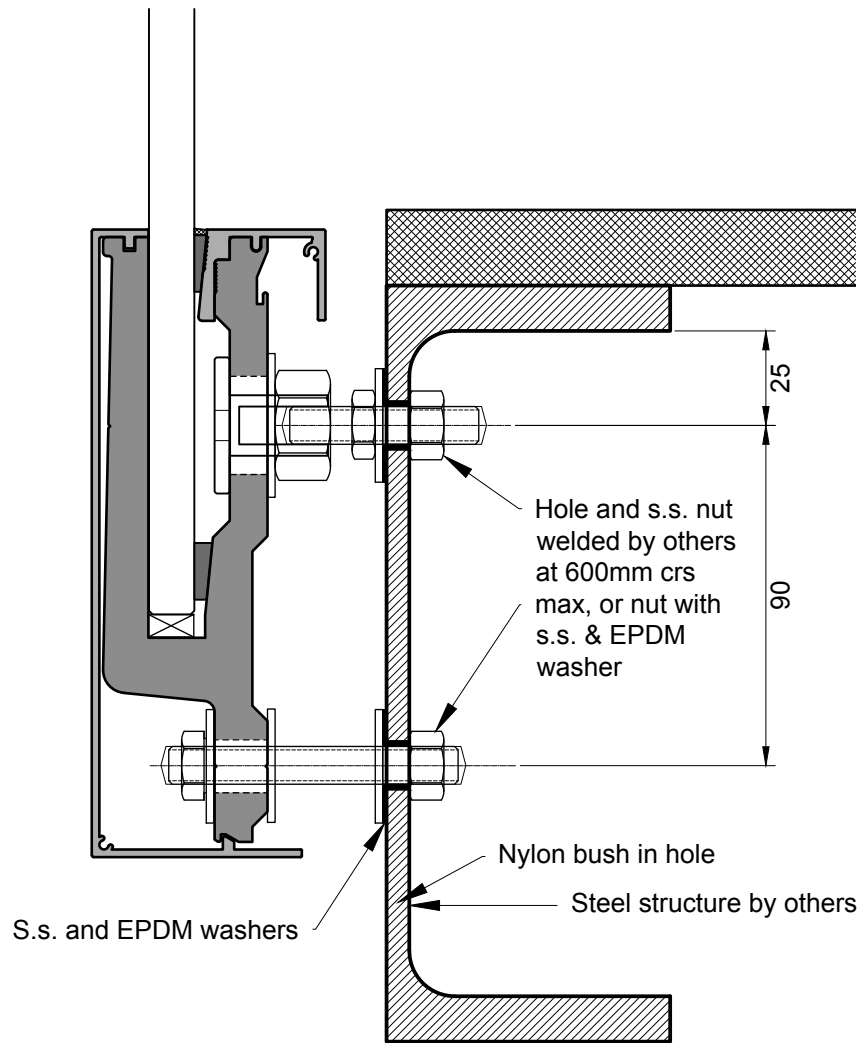

DETAIL A

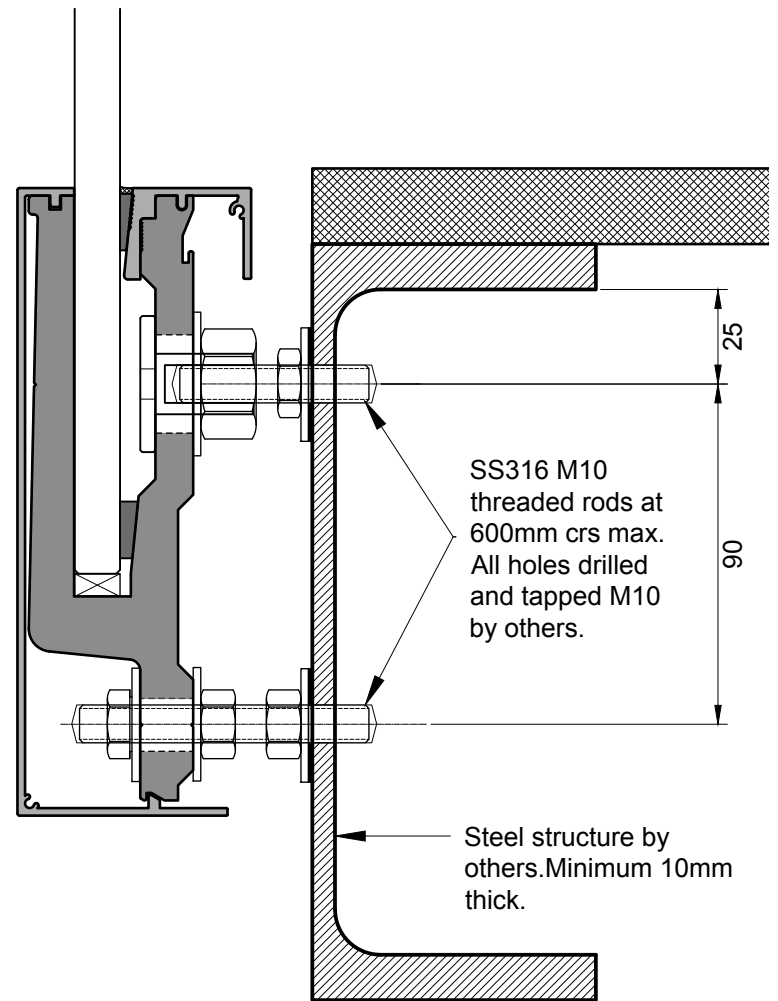

FOR INTERNAL INSTALLATION ONLY

DETAIL B

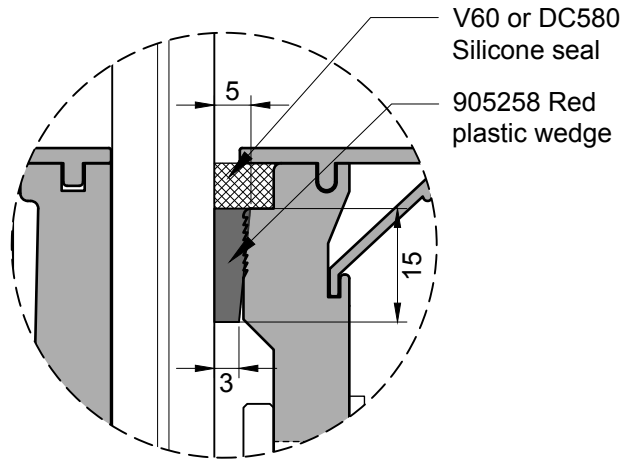

OPTION 1

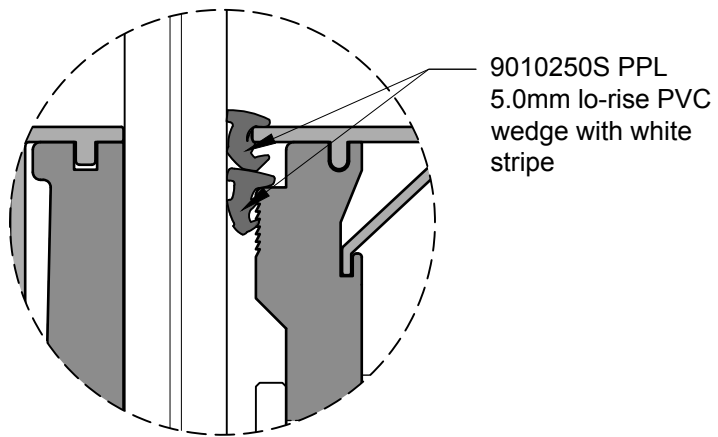

OPTION 2

