

NOTES:

1. This proprietary balustrade system complies with New Zealand Building Code Clauses B1 Structure, B1/AS1 Amendment 15, F2 Hazardous Building Materials and F4 Safety From Falling Third Edition, subject to:

-all products meeting the required performance specification
 -site installation carried out in accordance with intent of this drawing

2. Based on Viridian 12mm toughened or 13.5mm toughened laminated safety glass,, maximum height of glass above concrete floor for residential C3 of Table 3.3 AS/NZS 1170.1 are:

- Very high wind zone 1.76 kPa - 1100mm

3. Concrete design is the responsibility of others. Rockite or Kwikset grout to manufacturer's instructions.

4. A handrail of 32-50mm diameter is required for stairs and ramps exceeding 1:20 slope. Refer NZBC D1/AS1.

5. Viridian safety glass options according to 22.4.3 of NZS 4223.3:2016 are:

- a. 12mm toughened safety glass with interlinking rail
- b. 13.52mm toughened SentryGlas laminated glass with a minimum pane width of 1200mm

Interlinking rail must be connected to each glass pane or the building.

6. Maximum distance from side edge of glass to Eurobrace - 200mm.

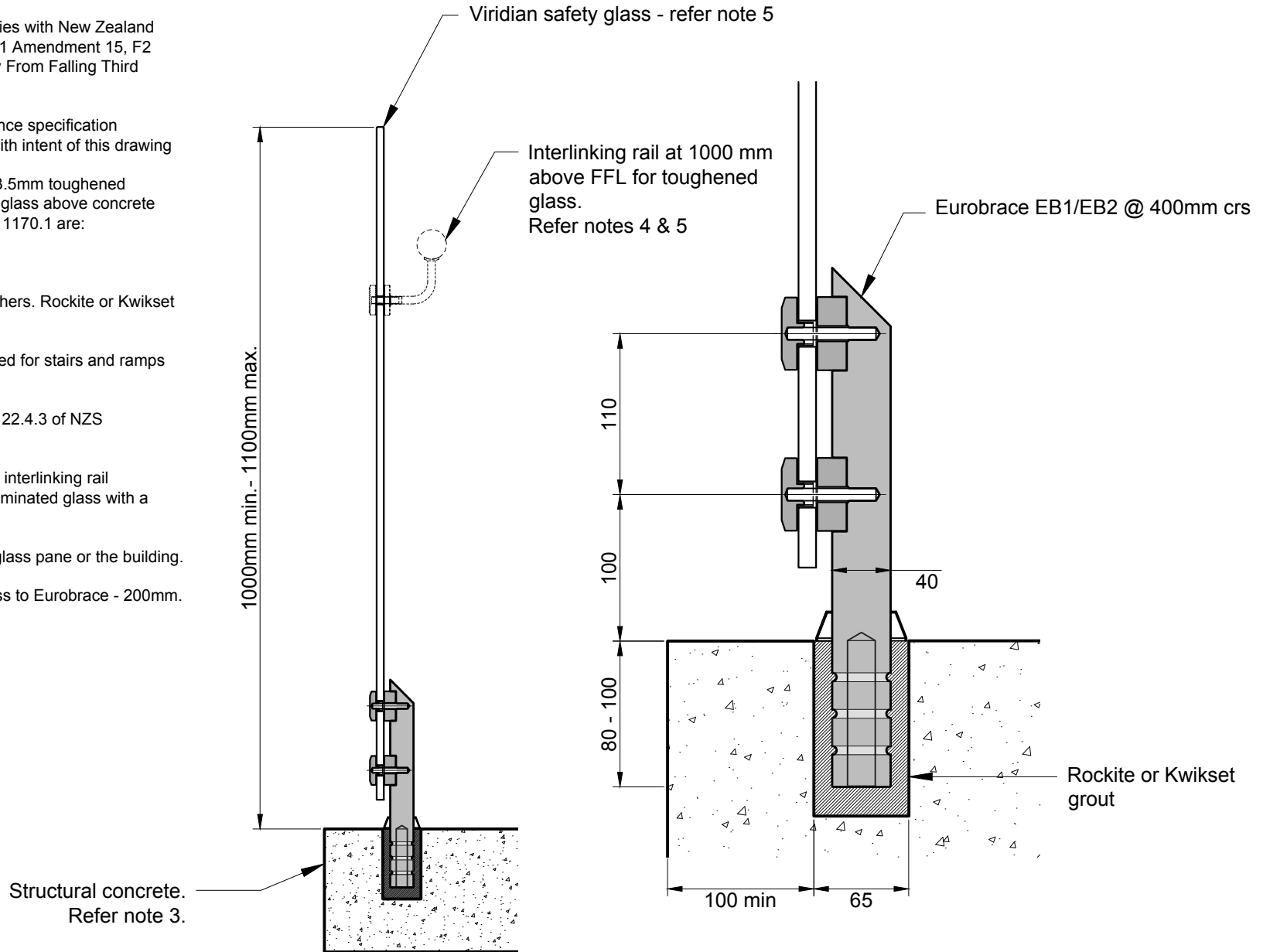

A division of Viridian Glass Ltd Partnership

EUROBRACE RESIDENTIAL BALUSTRADE

date 12-06-17

drawing no

scale 1:10, 1:4

EB-1e